



IIMK/WPS/12/IT/2007/01

**Shortest Path Routing in Multihop Packet
Switching Communication Network
using Genetic algorithm**

**Urmila Bhanja¹, Anjan Kumar Swain²,
Abani Mohan Panda³**

¹ Assistant Professor, Department of Electrical Engineering, I.G.I.T. Sarang, Orissa, India
Email: bjanjaurmila@hotmail.com

² Associate Professor, Indian Institute of Management Kozhikode, IIMK Campus PO-673570, Kerala, India
Email: akswain@iimk.ac.in

³ Professor, Department of Electrical Engineering, I.G.I.T. Sarang, Orissa, India

Shortest Path Routing in Multihop Packet Switching Communication Network using Genetic algorithm¹

This paper considers uni cast routing problem for networks where transmission requests are established by point to point connection. In this paper, the static routing problem of a given network has been formulated as a single objective optimization problem, and solved using a variant of genetic algorithms which minimizes the cost of existing links. Variable length chromosomes and their genes are used to encode the problem. The cost of existing links between different source and destination paths have been used to evaluate the fitness of chromosome. The crossover operator exchanges partial chromosomes at positionally independent crossing sites. The mutation provides the diversity of the population in the solution space by flipping of one of the genes of the candidate chromosomes, thereby keeping away from local optima. This algorithm has been tested on a known network of twenty nodes where the cost functions are known. It has also been calculated the average of best scores and the mean scores of all the individuals in a population pool after ten generations and fifty random trials.

1. Introduction

Finding an optimal route to transport certain traffic from a source node to a destination node is an important issue in optical network communication. The shortest path routing problem can be formulated either in terms of the physical distance or average number of hops the packet use to undergo between a particular source and destination, or in terms of cost of that particular link. Here, the cost of link usually depends on the use of the number of transmitters, receivers, wavelength converters on that link. Further, in multi hop network, routing is one of the most important issues that has a significant impact on the networks performance. It controls the cost of the whole network, as the average delay. An ideal routing algorithm should be capable of finding a path within a specified time so as to maintain the quality of services of a network. There exists several search algorithms for the shortest path problem such as the breadth-first search algorithm, the Dijkstra's algorithm and the Bellman Ford algorithm [10]. All these algorithms are capable of solving a shortest path problem in polynomial time and they are good for fixed wired or wireless topology. However, for dynamic changes in traffic or topology including node and link failure in real time incur high computational complexity. In this paper, the network considered facilitates dynamic node configuration without the help of any fixed infrastructure network. Further, optimal path need to be computed within a very short time for time constrained services like voice, video and teleconferencing application.

In this area, the published research works mainly concentrated on routing optimization to minimize maximum link load, optimization of the total fiber requirements and the fiber ports

¹ Referencing style followed: Journal of Information and Management, Elsevier B.V.

of each optical cross connect [3], and minimization the total fiber length [4]. There exists various methods to solve routing optimization problem with different objectives such as Integer Linear Programming, Heuristic Tabu search etc [11]. However, shortest path routing problems usually formulated as a classical combinatorial optimization problems are addressed well through neural networks and genetic algorithms to find near optimal solutions in various practical applications. Neural networks and Genetic algorithms are heavily based on objective function formulation and are stochastic in nature. These methods have been reported methods to give better results compared to classical methods. Further, these methods also try to give many potential solutions along with the optimal solutions, unlike other classical methods which output only one solution. Genetic algorithms can address network problems of any arbitrary size, unlike its neural counterpart that can accommodate networks of limited size. Therefore, Genetic algorithms are superior compared to other methods for finding a shortest route [1] for network of any size and dynamically changing topology. Genetic algorithms have been used for solving many combinatorial optimization problems like multicasting routing [2-3], ATM bandwidth allocation [2], capacity and flow assignment [4] dynamic routing [7], and shortest path routing [5].

This paper focuses only on the unicasting or one-source-to-destination problems, which can easily be extended for multicasting routing problems. Here, a new type of Genetic algorithm has been proposed for solving shortest path routing problem for a 20 node network. The proposed algorithm exhibits better solution with higher rate of convergence than other algorithms. Further, the results obtained are independent of network size and topologies. In this study, variable length chromosomes have been considered where the chromosomes are sequence of nodes generated randomly based on the available physical topology. The crossover exchanges part of the two chromosomes, whereas mutation introduces new chromosomes. The proposed GA employs a pair wise tournament selection without replacement with a very low mutation probability of 0.05. The mutation provides diversity in the population in the solution space by flipping of one of the genes of the candidate chromosome. Further, a repair function has been used to cure all the infeasible chromosomes which is generated after crossover operation instead of applying any penalty to all the infeasible individuals.

2. Proposed Algorithm

2.1. Problem Formulation

Any multihop physical topology network can be specified by the directed graph $G = (N, A)$, where N represents the total number of nodes (vertices) and A is a set of its links (arcs or edges). There is a cost C_{ij} associated with each link (i, j) . The costs are specified by the cost matrix $C = [C_{ij}]$, where C_{ij} denotes a cost of transmitting a packet from source S to destination D , respectively. There is a link connection indicator I_{ij} which is equal to one when the link is included in the path and is equal to zero when the link is not included in the path. Here, the shortest path routing problem has been formulated as a combinatorial optimization problem minimizing the objective function as follows:

Minimize

$$\sum_{i=S}^D \sum_{\substack{j=S \\ j \neq i}}^D C_{ij} I_{ij} \quad (1a)$$

Subject to

$$\sum_{\substack{j=S \\ j \neq i}}^D I_{ij} - \sum_{\substack{j=S \\ j \neq i}}^D I_{ji} = \begin{cases} 1, & \text{if } i = S \\ -1, & \text{if } i = D \\ 0, & \text{otherwise} \end{cases} \quad (1b)$$

and

$$\sum_{\substack{j=S \\ j \neq i}}^D I_{ij} \begin{cases} \leq 1, & \text{if } i \neq D \\ = 0, & \text{if } i = D \end{cases} \quad (1c)$$

$$I_{ij} \in \{0,1\}, \text{ for all } i$$

Above mentioned objective function (1a) minimizes the cost of a link from different source to destination nodes and the constraints (1b) and (1c) indicate the path without any loops.

2.2. Chromosome Representation

In this paper we have represented the paths as chromosomes. Each chromosomes are a sequence of nodes which are randomly generated and at the same time they satisfy the physical topology connectivity [1] of the particular network. The gene of the first locus always represents the source node. The length of the chromosomes are not same. We have taken variable length chromosomes. The length of chromosome should not exceed l where l represents the total number of nodes in the network, Since a routing path can never take more than l nodes. An example of chromosome representation is shown below. A chromosome is a routing path encoded from source node S to destination node D . The chromosome is essentially a list of nodes along the constructed path where l represents the total number of nodes.

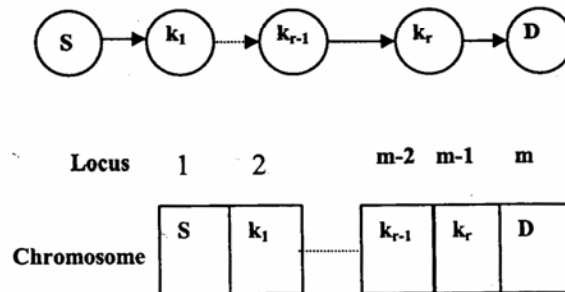

The first locus gene represents the source node always and the second locus node is generated randomly which is one of the physical connected node to the source node. In the encoding process each step of the path passes through a physical link in the network. This process continues till the destination node is reached. In the above figure k_1 represents the

neighboring node of the source node, k_2 represents the neighboring node of k_1 and so on till the destination node is reached.

2.3. Initialization of population

Two issues to be considered here for the initialization of population size: the initial population size and the procedure to initialize the population. Large population size gives better result sometimes, but it demands excessive costs in terms of both memory and time. Sometimes smaller population size also gives satisfactory results. Choosing adequate population size is very crucial. In this paper we have considered population size is equal to the number of nodes, l . When number of nodes increases the complexity of problem also increases.

Random initialization has been adopted to generate the initial population. The source node is fixed. The other nodes are generated randomly and at the same time they maintain the physical connectivity. The nodes are chosen randomly from the topological information data base. If there is any infeasible chromosome then care has been taken to refresh and reinitialize the chromosome or the path again.

2.4. Fitness Description

The fitness of a problem is based on its objective function. The fitness function evaluates the fitness of chromosome. It evaluates the quality of a chromosome in the entire population. The formulation of fitness function for a particular problem therefore plays a very major and crucial role. Since fitness function controls the quality of chromosome, it has to be formulated efficiently and accurately. The fitness function of GA is generally the objective function that requires to be optimized. It reflects the objective function. The fitness characteristic of a chromosome is better than others when that particular chromosome has higher fitness value. It is this fitness function which decides or selects the fittest chromosomes or more suitable chromosomes in the next generation.

The fitness function of the proposed algorithm depends on the cost matrix. The higher the cost of an existing link on the shortest path, the worst is the fitness of that chromosome, i.e., it lowers the value of the fitness function of that particular path or chromosome. The fitness function formulation for the given shortest path routing problem is given below:

$$f_i = \frac{1}{\sum_{j=1}^{k_i-1} C_{g_i(j),g_i(j+1)}} \quad (2)$$

The equation above represents the fitness function of i th individual, where f_i represents the fitness value of the i th chromosome, k_i is the length of the i th chromosome, $g_{i(j)}$ represents the gene of the j th locus of i th chromosome. C is the link cost between nodes.

2.5. Selection

The selection operator improves the quality of the population by selecting high quality chromosomes. The chromosomes are selected according to their fitness and get copied into the next generation. There are many selection operators. In the proposed algorithm we make use of binary tournament selection operator without replacement. This selection keeps noise as small as possible. In this selection process two chromosomes are selected randomly from the population pool and the fitter individual is selected to serve as parents for the next generation. While selecting the chromosomes care has been taken to see that the same selected chromosome does not get selected again.

2.6. Crossover

Usually two reproduction operators are used in the Genetic algorithm. Crossover is one where exchange of partial chromosomes (strings) of two chosen or selected chromosomes takes place. In the sp routing problem the crossover exchanges each partial route of two chosen chromosomes in such a manner that the offspring produced by the crossover represents only one route. In this process one partial route represents a route from a source node to an intermediate node and other represents a route from an intermediate node to a destination node.

The crossover used in the sp routing problem is not same as that of conventional one point crossover. In the proposed algorithm the two chromosomes are selected randomly [1] and they should have at least one common node or common gene apart from the source and destination node and it is not mandatory that the common node must be placed at the same locus or position of both the chromosomes. Therefore the crossover does not depend on the position of the nodes in the routing paths. The locus of the common node is itself the crossing site for those two chromosomes. If the two chosen chromosomes do not have any common node they are placed in the intermediate pool just like that without any crossover operation. If the two selected chromosomes have more than one common node then the crossing site for the crossover operation is chosen randomly, which is explained below with a figure.

Before crossover

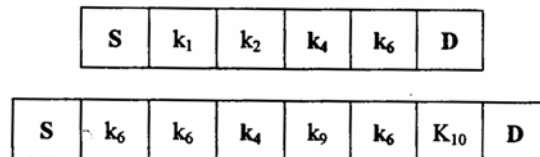

1st potential crossing site is (4, 4) which is node k₄
2nd potential crossing site is (5, 6) which is node k₆

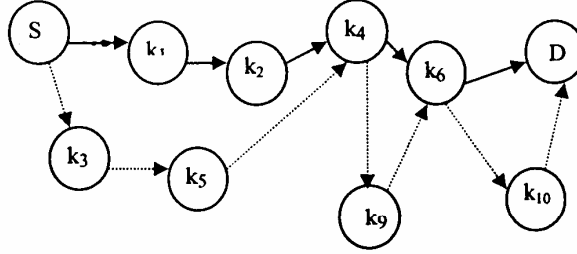

After crossover

**Crossing site is (5, 6) which is randomly chosen
Two off springs generated after crossover:**

S	K ₁	K ₂	K ₄	K ₆	K ₁₀	D
---	----------------	----------------	----------------	----------------	-----------------	---

S	K ₃	K ₅	K ₄	K ₉	K ₆	D
---	----------------	----------------	----------------	----------------	----------------	---

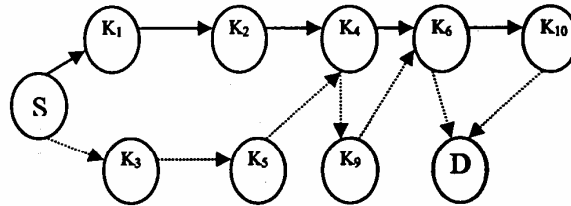

After crossover there may be chances of formation of loops in the chromosomes or the paths because of presence of same node in both the partial paths. So we have developed a repair methods to avoid these loops which otherwise never allow a packet to reach its destination.

2.7. Mutation

The mutation of chromosomes takes place by changing or flipping one of the genes of the candidate chromosomes to avoid the presence of local optima. In the proposed algorithm mutation probability of 0.05 is taken. Mutation side of the selected chromosome is chosen randomly. From that mutation node to destination node a partial new path is generated based on the physical topological [1] data base. While implementing the algorithm care should be taken so that no nodes get repeated which forms undesirable loop in the path.

Both crossover and mutation does exploitation and exploration in the search space to find better solution.

Before mutation

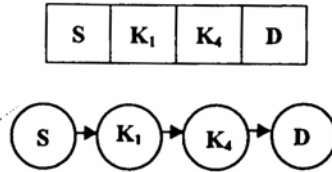

K₄ represents the mutation point

After mutation

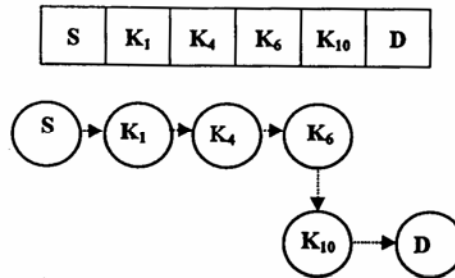

After mutation point k₄ the path searches for the next node randomly depending on the connectivity till destination node is reached.

2.8. Repair Method

The crossover may generate infeasible chromosomes which forms loop in the routing path. Care has been taken to generate feasible chromosome always after initialization and mutation.

A repair method [1] has been used to obtain feasible chromosomes. A classical method employs a penalty approach where penalty is given to each infeasible chromosome depending on its degree of infeasibility. But it is difficult to design an appropriate penalty function and also it is difficult to ensure quick convergence and high quality of solution. This technique may sacrifice some feasible chromosomes and may produce some infeasible chromosomes. Therefore the proposed repair method is best to use which eliminates the loop in a routing path without increasing the computational cost. This is explained in the figure below. One of the offspring becomes infeasible after crossover operation because the new route contains the loop k₂-k₄-k₂. The repair function detects the loop and repairs it.

Before repair function and before crossover

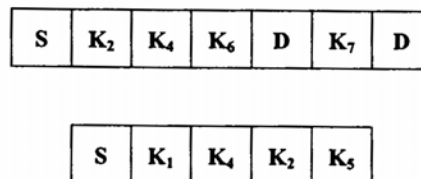

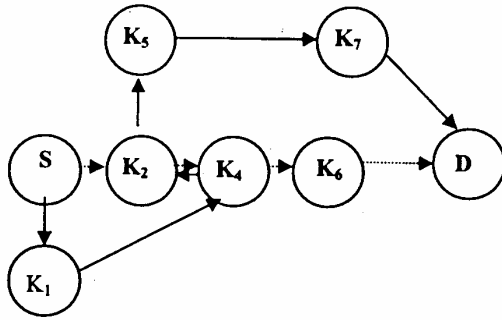

After crossover and before applying repair function

After crossover and before applying repair function we find one feasible and one infeasible chromosome and as shown below in the figure we find a loop in the infeasible chromosome.

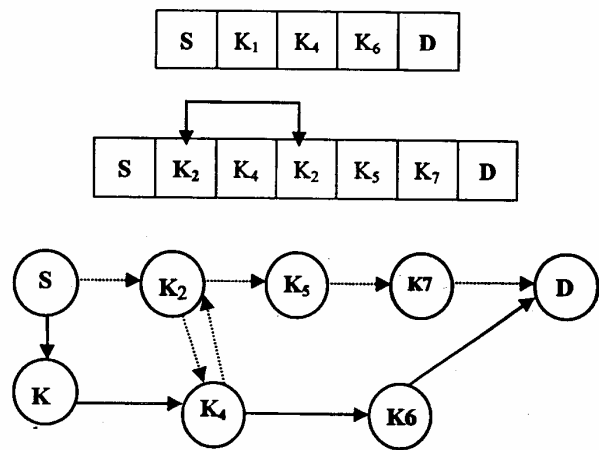

After applying repair function

As shown below in the figure after applying repair function the loop is eliminated and the chromosomes become feasible.

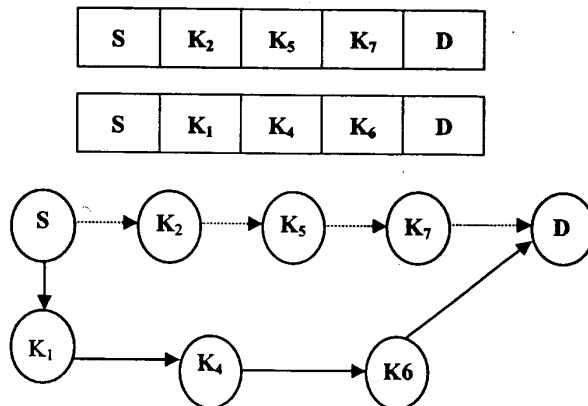

The loop $k_2-k_4-k_2$ is eliminated here

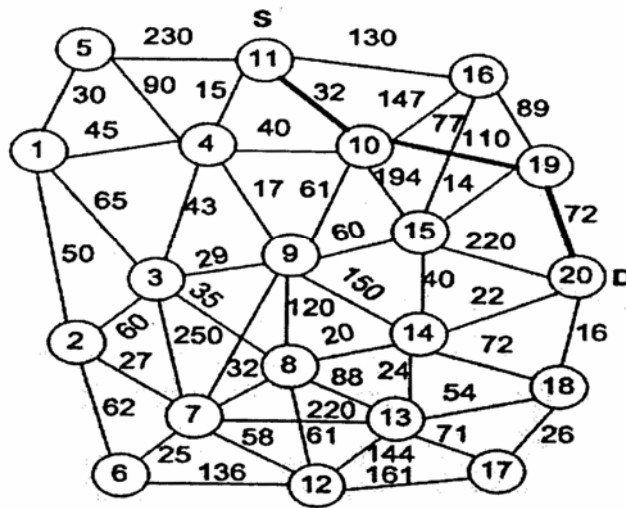

3.2. Fitness function values

The figure below shows the fitness function with generations and it implies that the proposed GA algorithm exhibits a very fast rate of convergence because the number of generations up to the convergence is the small.

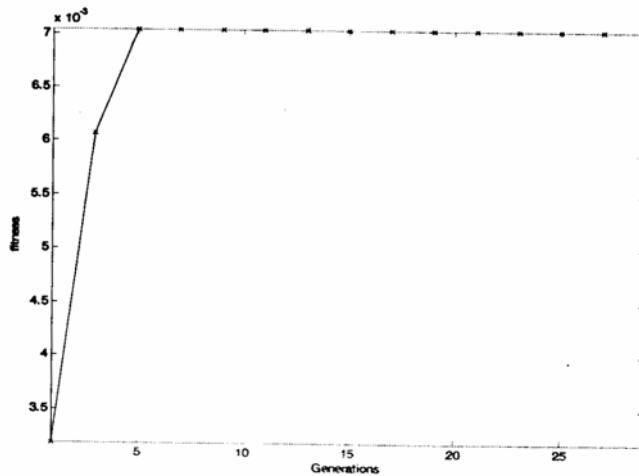
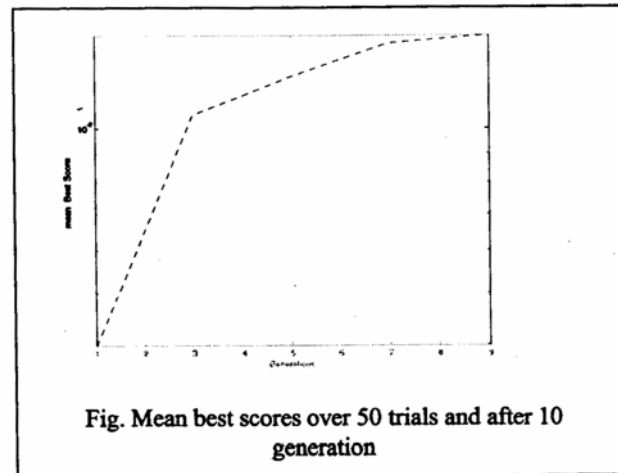
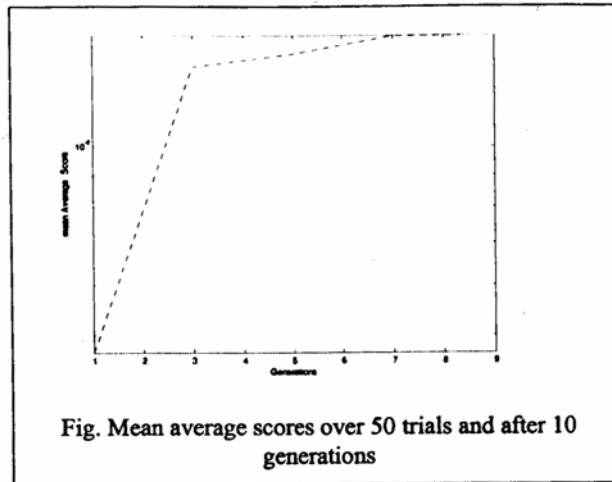

Fig. Average of best fitness scores and mean fitness scores

The figure below shows the average of best scores and mean scores after 10 generation and 50 different trials. The figure shows that the proposed algorithm exhibits much higher rate of convergence and at about 4th generation the mean average fitness and mean best fitness over 50 trials have been driven to a nearly constant level.



4. Conclusion and Further Scope

This paper presents a genetic algorithm for solving routing problem in a fixed static topology network. The crossover and mutation operator work on variable length chromosomes. The crossover is independent of crossing site. Both crossover and mutation play an important role and search the solution space in a very effective manner. Mutation avoids local optima and maintains the diversity of the population. A repair method is introduced to deal with infeasible chromosomes without any additional cost and computational complexity. Simulation shows that the proposed algorithm is not sensitive to variation in network topology. However for dynamic network topology hardware implementation of GA provides better solution than other methods.

The proposed algorithm can be extended for multicasting shortest path routing problem as well.

REFERENCE

- [1] Chang Wook Ahn, R.S. Ramakrishna "A Genetic Algorithm for Shortest Path Routing Problem and the Sizing of Populations," IEEE Tran on Evolutionary Computation, Vol.6, No.6 DECEMBER 2002.
- [2] H.Pan and I.Y.Wang, "The bandwidth allocation of ATM through genetic algorithm,"in proc, IEEE GLOBECOM'91, 1991, PP. 125-129.
- [3] J. Inagaki, M. Haseyama, and H. Kitajima,"A genetic algorithm for determining multiple routes and its applications,"in proc. IEEE Int Symp. Circuits and Systems, 1999, pp.137-140.
- [4] M.E. Mostafa and S.M.A. Eid,"A genetic algorithm for joint optimization of capacity and flow assignment in packet switched networks," in Proc. 17th National Radio Science Conf;2000,pp.C5-1-C5-6.
- [5] M. Munemoto, Y Takai, and Y.Sato,"A migration scheme for the genetic adaptive routing algorithm," in proc.IEEE Int Conf. System,Man, and Cybernetics, 1998,pp.2774-2779.
- [6] N. Nagatsu, Y. Hamazumi, and K.Sato, "Optical path cross connect system scale evaluation using path accommodation design for restricted wavelength multiplexing,"IEEE J. Select Areas Commun; Vol 14, pp.893-203, June, 1996.
- [7] N. Shimamoto, A. Hiramatsu, and K. Yamasaki, "A dynamic routing control based on genetic algorithm,"in proc.IEEE Int. Conf. Neural Networks, 1993, pp.1123-1128.
- [8] Q. Zhang and Y.W.Leung, "An orthogonal genetic algorithm for multimedia multicasting routing," IEEE Trans. Evol. Comput; vol3, pp.53-62, Apr.1999.
- [9] R.Inkret, B.Mikac, I.Podnar, "A heuristic approach to wavelength assignment in all optical networks, "MELECON Proceedings of the 1998 9th Mediterranean Electrotechnical Conference, May 18-20 1998 Vol.2 pp. 759-763 1998.
- [10] W. Stalling, High speed Networks: TCP/IP and ATM Design Principles. Eaglewood Cliffs, NJ: Prentice-Hall, 1998.
- [11] Yoshiyuki Hamazumi, Naohide Nagatsu, Satoru Okamoto, Ken-ichi Sato, "Optical path Accomodation Designs Applicable to Large Scale Network, "IEICE Trans. Commun; Vol.-78-B, No.4, pp.597-607, Apr.1995.
- [12] Z. Xiawei, C. Changjia, and Z.Gang," A Genetic algorithm for multicasting routing problem," in Proc. Int. Conf. Communication Technology, 2000, pp.1248-1253.



Indian Institute of Management Kozhikode

<i>Type of Document</i> (Working Paper/Case/Teaching Note, etc.) <p style="text-align: center;">Working Paper</p>	<i>Ref. No.:</i> <p style="text-align: center;">IIMK/WPS/12/IT/2007/01</p>
<i>Title:</i> <p style="text-align: center;">Shortest Path Routing in Multihop Packet Switching Communication Network using Genetic algorithm</p>	
<i>Author(s) & Contact Details :</i> <ol style="list-style-type: none"> 1. Anjan Kumar Swain, Associate Professor, Indian Institute of Management Kozhikode IIMK Campus PO-673570, Kozhikode, Kerala, India Ph: (91-495) 2809122, email:akswain@iimk.ac.in 2. Urmila Bhanja, 3. Abani Mohan Panda, 	<i>Institution(s):</i> <ol style="list-style-type: none"> 1. Indian Institute of Management Kozhikode, Kozhikode, Kerala, India. 2. Department of Electrical Engineering, IGIT Sarang, Orissa, India. 3. Department of Electrical Engineering, IGIT Sarang, Orissa, India
<i>Subject Areas:</i> Information Technology	<i>Subject Classification Codes, if any:</i>
<i>Supporting Agencies, if any:</i>	<i>Research Grant/Project No.(s):</i>
<i>Supplementary Information, if any:</i>	<i>Date of Issue:</i> January 2007 <hr/> <i>Number of Pages:</i> 12
<i>Abstract:</i> <p>This paper considers uni cast routing problem for networks where transmission requests are established by point to point connection. In this paper, the static routing problem of a given network has been formulated as a single objective optimization problem, and solved using a variant of genetic algorithms which minimizes the cost of existing links. Variable length chromosomes and their genes are used to encode the problem. The cost of existing links between different source and destination paths have been used to evaluate the fitness of chromosome. The crossover operator exchanges partial chromosomes at positionally independent crossing sites. The mutation provides the diversity of the population in the solution space by flipping of one of the genes of the candidate chromosomes, thereby keeping away from local optima. This algorithm has been tested on a known network of twenty nodes where the cost functions are known. It has also been calculated the average of best scores and the mean scores of all the individuals in a population pool after ten generations and fifty random trials.</p>	
<i>Key Words/Phrases:</i>	
<i>Referencing Style Followed:</i> Journal of Information and Management, Elsevier B.V.	